

H900-HP SERIES

HAM-LET RELIEF VALVES



Set Pressure from 50 psig to 6,000 psig (3.50 TO 414 BAR G)
 Made from A.I.S.I. 316.
 Available with threaded or Let-Lok connectors.
 Sizes: 1/4" or 6mm.







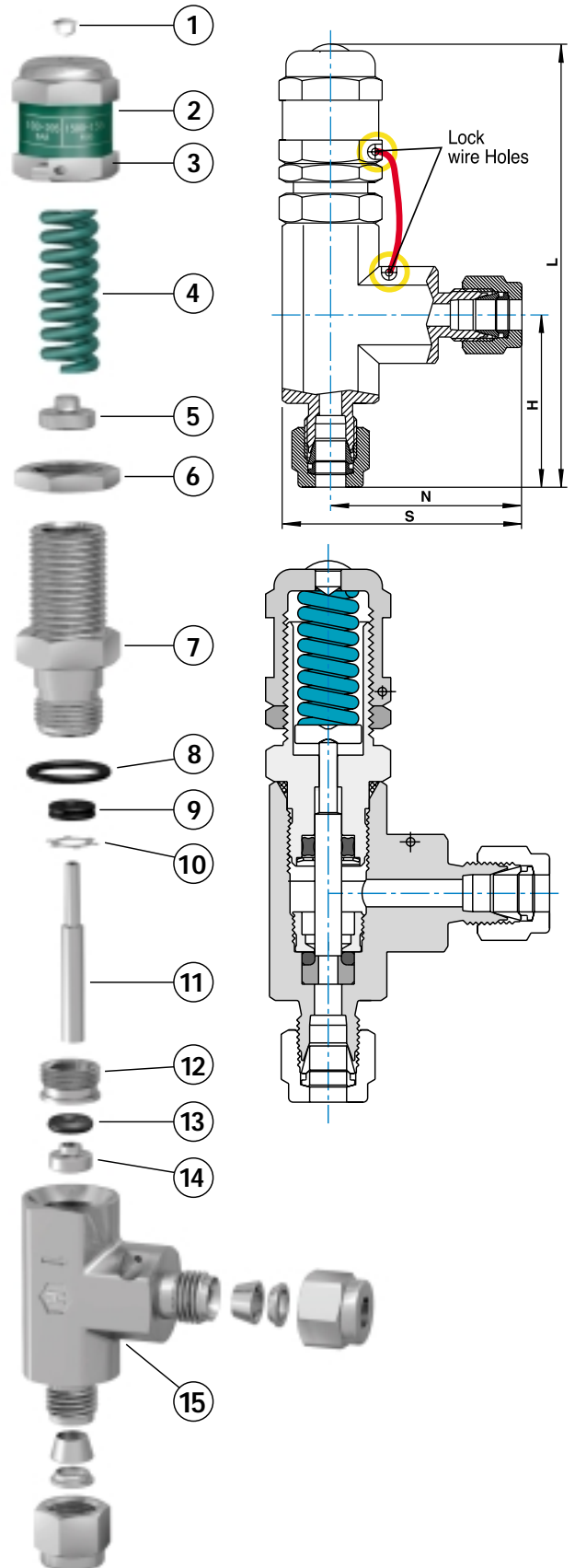

Dimensions:

Cat. No	Connection/Size		H	N	S	L
	inlet	outlet				
H-900	1/4 LET-LOK	1/4 LET-LOK		39	50	105
H-900	6mm LET-LOK	6 mm LET-LOK	37	39	50	105
H-985	1/4 Male NPT	1/4 Female NPT		30	40	100
H-995	1/4 Male NPT	1/4 LET-LOK	32	39	50	100

Materials of Construction

	NAME	MATERIAL	QTY.
1	Cap Plug	P.T.F.E	1
2	Label	PVC	1
3	Adjustment Cap	A.I.S.I. 316	1
4	Spring	A.I.S.I. 302,17-7PH	1
5	Lower Spring Button	A.I.S.I. 316	1
6	Locking Nut	A.I.S.I. 316	1
7	Bonnet	A.I.S.I. 316	1
8	O-Ring	Viton	1
9	Quad Ring	Viton	1
10	Retaining Ring	PH15-7Mo	1
11	Poppet	A.I.S.I. 316	1
12	Clamps Screw	A.I.S.I. 316	1
13	O-Ring	Viton	1
14	Insert	A.I.S.I. 316	1
15	Body	A.I.S.I. 316	1



Nominal Cracking Pressure Range		Psig	Bars	Spring Designator.	Color
		50-350	3.4 - 24	A	White
		350-750	24 - 51.5	B	Blue
		750-1500	51.5 - 103	C	Gold
		1500-2250	103 - 155	D	Turquoise
		2250-3000	155 - 206	E	Green
		3000-4000	206 - 275	F	Red
		4000-5000	275 - 344	G	Silver
		5000-6000	344 - 413	H	Black

Temperature Range 0°F-250°F/-18°C-121°C

Flow Capacity (Cv)

1/4 inch Orifice 3.4 mm Cv = 0.42

The Cv factor is a flow coefficient expressing the rate of flow in U.S. gallons per minute of water at 60°F (16°C) with a pressure drop of 1 psi across the valve. The flow depends on the inlet and outlet pressures, temperature, specific gravity and the Cv coefficient.

For Liquids at 60°F (16°C)

$$Cv = \frac{USGPM}{\sqrt{\frac{(\Delta P)}{(SG)}}} \text{ OR } USGPM = Cv \sqrt{\frac{(\Delta P)}{(SG)}}$$

Where:

- ΔP = P₁ - P₂ in PSI
- P₁ = Inlet pressure in PSIA
- P₂ = Outlet pressure in PSIA
- USGPM = Flow in US gallons per minute
- SG = Specific gravity of liquid (water = 1 at 60°F)

For Gas at 70°F (21°C)

$$Cv = \frac{SCFH}{1360 \sqrt{\frac{(\Delta P)(P_1)}{(460+T)(SG)}}} \text{ OR } SCFH = 1360Cv \sqrt{\frac{(\Delta P)(P_1)}{(460+T)(SG)}}$$

Where:

- ΔP = P₁ - P₂ in PSI
- P₁ = Inlet pressure in PSIA
- P₂ = Outlet pressure in PSIA
- SCFH = Flow in standard cubic feet per hour
- SG = Specific gravity of gas (air = 1 at 70°F (21°C) and 14.7 PSIA (1 ATM.))
- T = Temperature in °F

Note: Maximum ΔP for compressible fluids is $\frac{P_1}{2}$

NOTES.

1. Valves are not set at any specific pressure when they leave the factory.
2. Valves may not lift at the original cracking pressure if they have not been actuated for an extended period of time.

How to Order

H900-HP	SS	L	1/4	Spring Designator
Body Designator 900-LET-LOK to LET-LOK	Material Designator SS=316SS	Connections Designator L=LET-LOK N=NPT NL=NPT to LETLOK	Size Designator	See Table Above

For other materials and end connections consult factory engineering dept.

Warning! For Your Safety

The system designer and user have the sole responsibility to select products suitable for their special application requirements to ensure the proper installation, operation and maintenance of the product. Application details, material compatibility and product ratings should all be considered in the individual selection. Improper selection or use of products can cause property damage or personal injury.